

IVECO  **S-WAY**

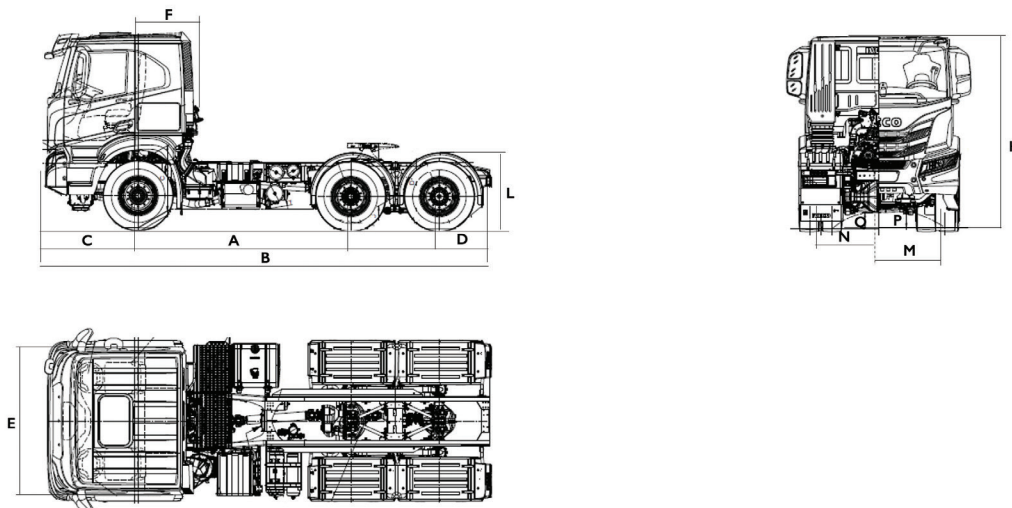

AT440S43TZ OFF – 6x4 Truck Tractor, Mechanical Suspension



Dimensions (mm)

A	Wheelbase	3 300
	Tandem	1 395
B	Overall length (over bumpers)	6 939
C	Front overhang	1 440
D	Rear overhang	778
E	Cab width	2 300
F	Cab gap	940
K	Cab height (unladen)	3 102
L	Frame height at rear axle (unladen)	1 029
	Just 37C 5th wheel height (unladen) – (H=185; MP=40)	1 254
	Frame thickness	7.7
	Turning circle (kerb to kerb)	16 800
	Turning circle (wall to wall)	18 400
M	Front track	2 044
N	Rear track	1 820
	Ground clearance (front bumper)	504
P	Ground clearance (front axle)	316
Q	Ground clearance (rear axle)	250
α	Approach angle	28°
β	Departure angle	39°

Tyres

Standard tyres: Michelin X-Multi Z-D 315/80R22.5, on Alcoa Diamant Rims

Weights (kg)

	Front axle	Rear axle unit	Gross vehicle weight	Gross combination weight
Design weights	8 000	21 000	28 000	60 000
Permissible weights	7 700	18 000	25 700	56 000
Kerb weights	4 972	3 624	8 596	

Engine

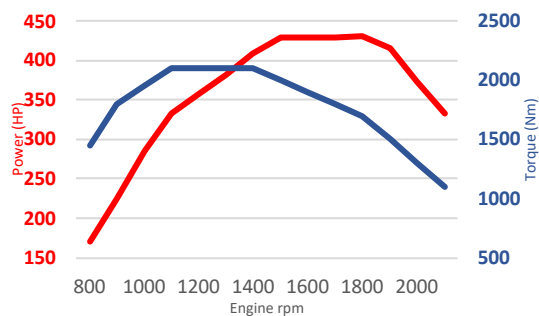

Iveco Cursor 13 F3HGE611 Engine

Turbocharger	Waste gate
Cylinders in line	6
Bore (mm)/Stroke (mm)	135/150
Capacity (litres)	12,88
Max power (HP/kW)	430/321 @ 1500 rpm
Max torque (Nm)	2100 @ 1100 rpm
Engine Brake Power (kW)	306
Cooling fan	Electro-magnetic
Fuel system	Common rail - high pressure
Engine idle cut-off	Standard

Transmission**I2TX 2420 TD Hi-Tronix Direct Drive Gearbox with Intarder**

Ratio 1st gear	16.69
Ratio 12th Gear	1
Ratio 1st reverse	15.54
Ratio 2nd reverse	12.03
PTO	NH/4c direct pump mount
Innovations	Eco-roll Eco-switch Rocking mode

Clutch

Type	Single dry plate
Diameter	(17") 430 mm

Axles

Front	Iveco 5890/OFF
Rear	MT23-150/D. Single reduction
Rear axle ratio	3.09
Gradeability in 1st gear at 56t on GCM (%)	36.78
Gradeability in 1st gear at 56t on GCM (%)	1.27

Suspensions

Front	Parabolic
Rear	Parabolic
Stabilizer bar	Front and rear
Shock absorbers	Front and rear

Steering

Type	ZF 8098, power assisted
Steering wheel diameter	470mm

Brakes

Type	2 independent pneumatic circuits
Service	E.B.S. + B.A.S Incorporates: <ul style="list-style-type: none"> • ABS (Anti-Lock Braking System). • ASR (Anti-skid regulator). • DBI (Direct Brake Integration). • BAS (Brake Assistant System). • BVR (Brake Lining Wear Adjustment). • ARB (Hill Holder)
Front axle	Ventilated discs. 432 mm; Friction area: 784 cm ²
Rear axles	Ventilated discs. 432 mm; Friction area: 784 cm ²
Parking	Mechanical with spring cylinder, drive axle
Emergency	Combined with parking brake
Air compressor	630cc twin barrel
Heated air dryer	Air processing unit
Trailer connections	15-pin plug

Fuel tank

Material & capacity	Aluminium, 540l with anti-siphon device
---------------------	---

Electronics

Voltage	24V, negative earth return
Alternator	28V, 90A
Starter	24V, 5.5kW
Batteries	2x12V, 220Ah
Circuits protected	By fuse
System	Multiplex - CAN line data bus
Headlights	Full LED + fog lights with cornering support

Taillights

LED round taillights

FMS Connectivity

FMS Gateway

Cab

- AT – Active Time cab with low roof.

Cab exterior

- 2.3m wide cab.
- Forward control sleeper cab.
- Galvanised pressed steel construction with SMC for vulnerable parts.
- Mechanical cab suspension.
- Mechanical cab tilt to 60 deg.
- Tinted electric door windows and tinted laminated screen.
- Heated, electrically adjustable rear-view mirrors, plus kerb, wide-angle and front view mirrors according to 2003/97/EC.
- Steel front bumper.
- Steel radiator guard.
- Flexible bottom step.

**Cab Interior**

- Fabric air suspended driver seat with safety belt and headrest.
- Fabric passenger seat with safety belt and headrest.
- Pneumatic horn.
- Manually controlled air conditioning.
- DAB Bluetooth® radio.
- Driver side sunblind.
- 2 keys with immobiliser.
- Jack.
- Bunk with storage compartment.

